

Radioactive Box

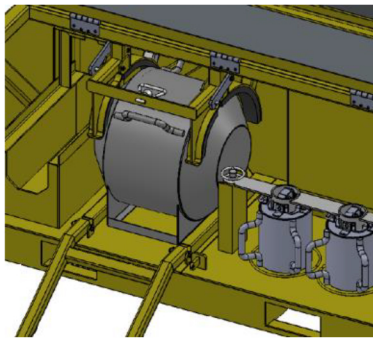

Uniteam Offshore Radioactive box are designed, manufactured and certified in accordance with DNVGL 2.7-1, as well as EN 12079, It will transport and storage radioactive material in platform.

The tool box have various sizes and for different purposes according to client requirement.

General specification:

- Radioactive equipment can be easy put into and taken out from the frame.
- Equipment need to be fixed well without damage.

Certification:

- DNVGL 2.7-1 certificate

Specification

	WEIGHT (kg)			EXTERNAL DIMENSIONS (mm)		
	TARE	PAYLOAD	MGW	LENGTH	WIDTH	HEIGHT
Radioactive box	498	500	998	1650	768	800
	1200	3800	5000	2000	1700	1200

The above are standard dimensions; other sizes may be supplied on request.